

SECTION **CL**

CONTENTS

| | | | |
|---|----|---|----|
| PRECAUTIONS | 2 | Installation..... | 16 |
| Precautions | 2 | | |
| PREPARATION | 3 | <input type="text"/> RS5F30A, RS5F70A <input type="text"/> | |
| Special Service Tools | 3 | CLUTCH RELEASE MECHANISM | 17 |
| Commercial Service Tools | 3 | Components..... | 17 |
| NOISE, VIBRATION AND HARSHNESS (NVH) | | Removal..... | 17 |
| TROUBLESHOOTING | 4 | Inspection..... | 17 |
| NVH Troubleshooting Chart..... | 4 | Installation..... | 17 |
| CLUTCH | 4 | | |
| CLUTCH SYSTEM | 5 | <input type="text"/> RS5F50A <input type="text"/> | |
| Components - RHD Model with QG Engine - | 5 | CLUTCH RELEASE MECHANISM | 20 |
| Components - LHD Model with QG Engine - | 6 | Components..... | 20 |
| Components - RHD Model with YD Engine - | 7 | Removal..... | 20 |
| Components - LHD Model with YD Engine - | 8 | Inspection..... | 20 |
| Inspection and Adjustment | 9 | Installation..... | 20 |
| CLUTCH PEDAL INSPECTION | 9 | | |
| CLUTCH PEDAL ADJUSTMENT | 10 | <input type="text"/> <input type="text"/> | |
| AIR BLEEDING PROCEDURE | 10 | CLUTCH DISC, CLUTCH COVER AND FLYWHEEL | 22 |
| CLUTCH MASTER CYLINDER | 11 | Components..... | 22 |
| Components..... | 11 | Inspection and Adjustment | 22 |
| Removal..... | 12 | CLUTCH DISC..... | 22 |
| Installation..... | 12 | CLUTCH COVER..... | 23 |
| Disassembly..... | 12 | FLYWHEEL | 23 |
| Inspection..... | 12 | Installation..... | 23 |
| Assembly | 13 | SERVICE DATA AND SPECIFICATIONS (SDS) | 24 |
| OPERATING CYLINDER | 14 | Clutch Control System..... | 24 |
| Components..... | 14 | Clutch Master Cylinder | 24 |
| Removal..... | 14 | Clutch Operating Cylinder | 24 |
| Disassembly..... | 14 | Clutch Disc..... | 24 |
| Inspection..... | 14 | Clutch Cover | 24 |
| Assembly | 15 | Clutch Pedal | 24 |
| Installation..... | 15 | | |
| PIPING | 16 | | |
| Removal..... | 16 | | |

PRECAUTIONS

Precautions

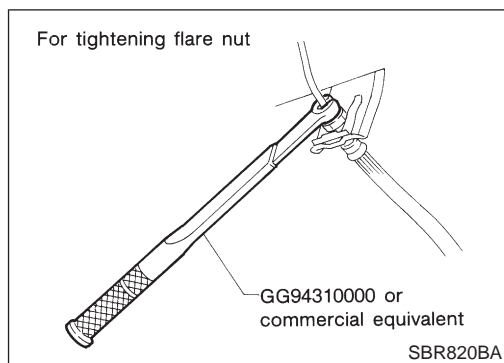

Precautions

NJCL0001

- Recommended fluid is brake fluid “DOT 4”. Refer to MA-16, “Fluid and Lubricants”.
- Never reuse drained brake fluid.
- Be careful not to splash brake fluid on painted areas.
- When removing and installing clutch piping, use Tool.
- Use new brake fluid to clean or wash all parts of master cylinder and operating cylinder.
- Never use mineral oils such as gasoline or kerosene. It will ruin the rubber parts of the hydraulic system.

WARNING:

After cleaning clutch disc, wipe it with a dust collector. Do not use compressed air.

PREPARATION

Special Service Tools

Special Service Tools

NJCL0002

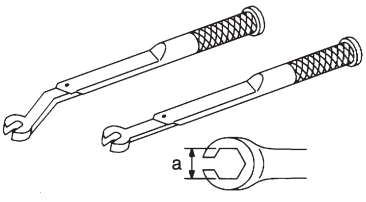
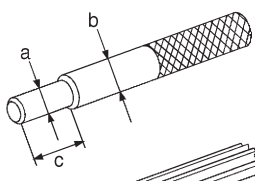
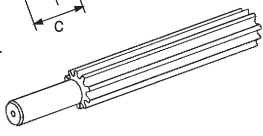
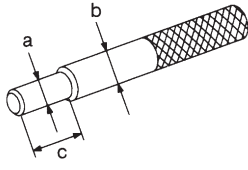
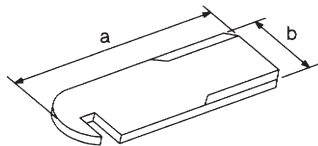
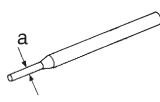
| Tool number Tool name | Description | |
|--|--|--|
| GG94310000 Flare nut torque wrench |  | Removing and installing clutch piping a: 10 mm (0.39 in) |
| NT406 | | |
| KV30101600 (New) KV30101000 (Former) Clutch aligning bar | <p>New</p>  <p>Former</p>  | Installing clutch cover and clutch disc (F30A and F70A) a: 15.9 mm (0.626 in) dia. b: 17.9 mm (0.705 in) dia. c: 40 mm (1.57 in) |
| NT645 | | |
| ST20630000 Clutch aligning bar |  | Installing clutch cover and clutch disc (F50A) a: 15.8 mm (0.622 in) dia. b: 22.9 mm (0.902 in) dia. c: 45.0 mm (1.772 in) |
| NT405 | | |
| ST20050240 Diaphragm spring adjusting wrench |  | Adjusting unevenness of diaphragm spring of clutch cover a: 150 mm (5.91 in) b: 25 mm (0.98 in) |
| NT404 | | |
| KV32101000 Pin punch |  | Removing and installing spring pin a: 4 mm (0.16 in) dia. |
| NT410 | | |

Commercial Service Tools

NJCL0003

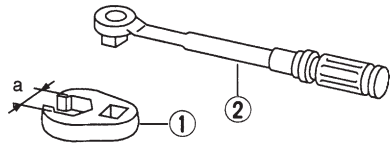
| Tool name | Description | |
|---|---|--|
| 1 Flare nut crowfoot 2 Torque wrench |  | Removing and installing clutch piping a: 10 mm (0.39 in) |
| NT360 | | |

NOISE, VIBRATION AND HARSHNESS (NVH) TROUBLESHOOTING

NVH Troubleshooting Chart

NVH Troubleshooting Chart

NVCL00004S01

Use the chart below to help you find the cause of the symptom. The numbers indicate the order of the inspection. If necessary, repair or replace these parts.

CLUTCH

NVCL00004S0101

| Symptom | SUSPECTED PARTS (Possible cause) | | Reference page | |
|---------------------------|-------------------------------------|---------------------|--|---|
| | Clutch grabs/chatters | Clutch pedal spongy | | |
| Clutch does not disengage | 1 | | CLUTCH PEDAL (Free play out of adjustment) | CL-10 |
| | | 1 | CLUTCH LINE (Air in line) | CL-10 |
| | | 2 | MASTER CYLINDER PISTON CUP (Damaged) | CL-11 |
| | | 2 | OPERATING CYLINDER PISTON CUP (Damaged) | CL-14 |
| | | 1 | ENGINE MOUNTING (Loose) | Refer to EM-137, "Removal and Installation" (QG engine model) and EM-137, "Removal and Installation" (YD engine model). |
| | | 1 | RELEASE BEARING (Worn, dirty or damaged) | CL-17 (RS5F30A, RS5F70A), CL-20 (RS5F50A) |
| | 5 | | CLUTCH DISC (Out of true) | CL-22 |
| | 5 | 2 | CLUTCH DISC (Runout is excessive) | CL-22 |
| | 5 | | CLUTCH DISC (Lining broken) | CL-22 |
| | 5 | | CLUTCH DISC (Dirty or burned) | CL-22 |
| | 5 | 2 | CLUTCH DISC (Oily) | CL-22 |
| | | 2 | CLUTCH DISC (Worn out) | CL-22 |
| | | 2 | CLUTCH DISC (Hardened) | CL-22 |
| | 5 | | CLUTCH DISC (Lack of spline grease) | CL-22 |
| | 6 | 3 | DIAPHRAGM SPRING (Damaged) | CL-23 |
| | 6 | | DIAPHRAGM SPRING (Out of tip alignment) | CL-23 |
| | 7 | 4 | PRESSURE PLATE (Distortion) | CL-23 |
| | | 5 | FLYWHEEL (Distortion) | CL-23 |

CLUTCH SYSTEM

Components — RHD Model with QG Engine —

Components — RHD Model with QG Engine —

NJCL0041

SEC. 300•305•306•465

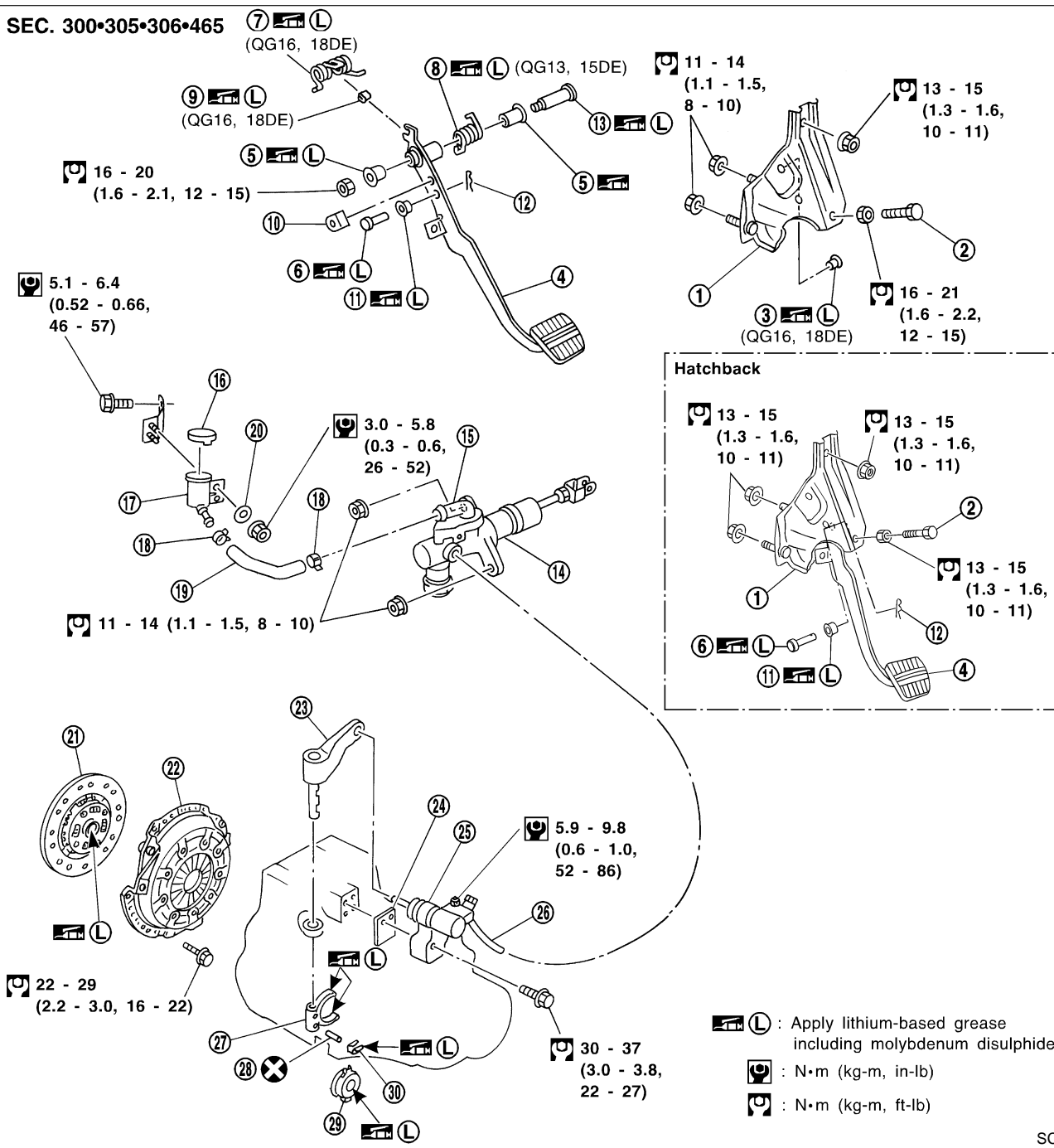

SCL843-A

- | | | |
|-------------------------|----------------------------|----------------------------|
| 1. Clutch pedal bracket | 11. Bush | 21. Clutch disc |
| 2. Pedal stopper bolt | 12. Snap pin | 22. Clutch cover |
| 3. Bush | 13. Fulcrum pin | 23. Withdrawal lever |
| 4. Clutch pedal | 14. Clutch master cylinder | 24. Spacer |
| 5. Bush | 15. Nipple | 25. Operating cylinder |
| 6. Clevis pin | 16. Reservoir cap | 26. Clutch hose |
| 7. Assist spring | 17. Reservoir tank | 27. Clutch lever |
| 8. Return spring | 18. Hose clamp | 28. Spring pin |
| 9. Bush | 19. Hose | 29. Release bearing |
| 10. Stopper rubber | 20. Washer | 30. Release bearing spring |

CLUTCH SYSTEM

Components — LHD Model with QG Engine —

Components — LHD Model with QG Engine —

NJCL0048

SEC. 300-305-306-465

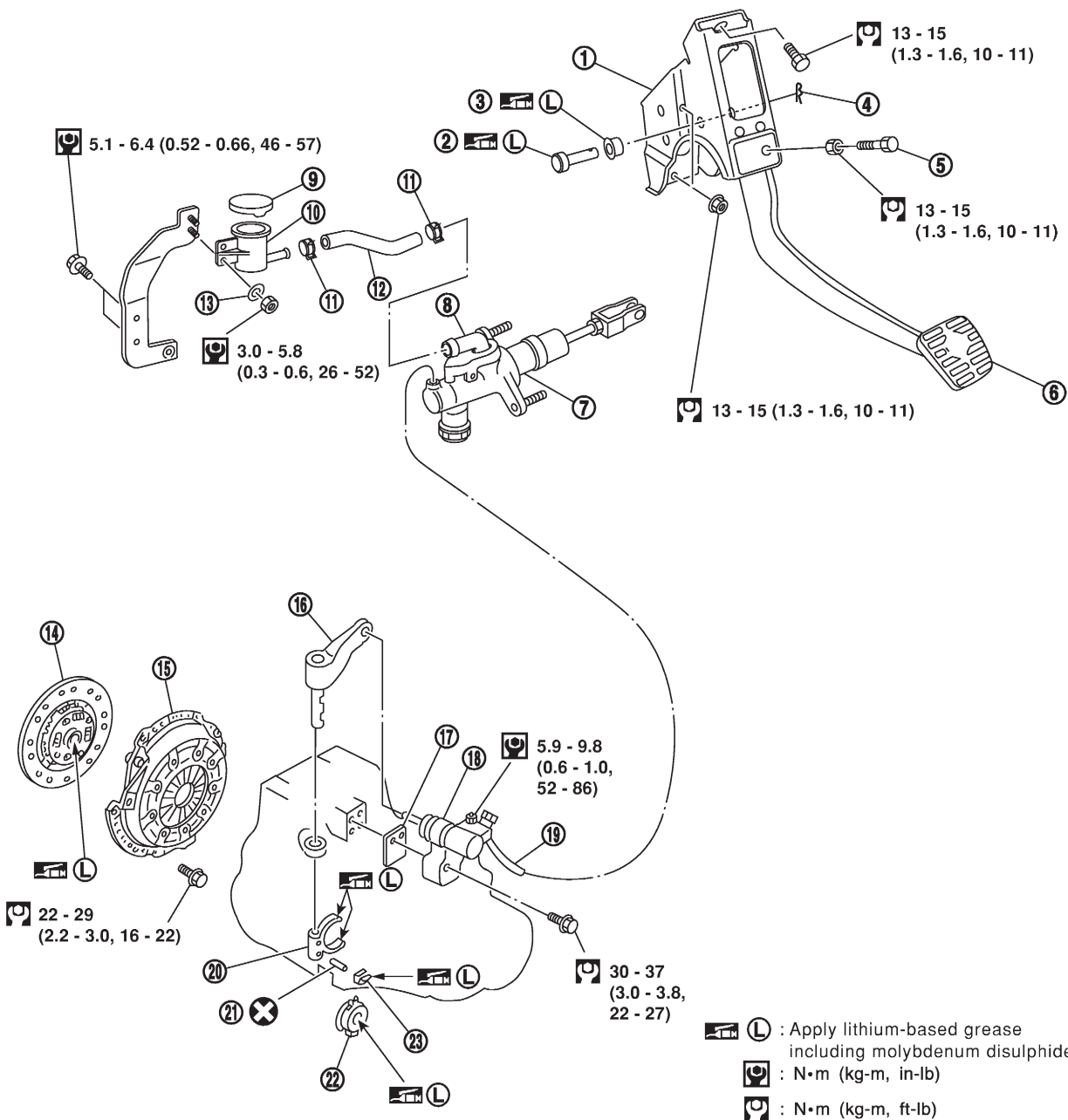

SCL844

- | | | |
|---------------------------|----------------------|----------------------------|
| 1. Clutch pedal bracket | 9. Reservoir cap | 17. Spacer |
| 2. Clevis pin | 10. Reservoir tank | 18. Operating cylinder |
| 3. Bush | 11. Hose clamp | 19. Clutch hose |
| 4. Snap pin | 12. Hose | 20. Clutch lever |
| 5. Pedal stopper bolt | 13. Washer | 21. Spring pin |
| 6. Clutch pedal | 14. Clutch disc | 22. Release bearing |
| 7. Clutch master cylinder | 15. Clutch cover | 23. Release bearing spring |
| 8. Nipple | 16. Withdrawal lever | |

CLUTCH SYSTEM

Components — RHD Model with YD Engine —

Components — RHD Model with YD Engine —

NJCL0005

SEC. 300•305•306•465

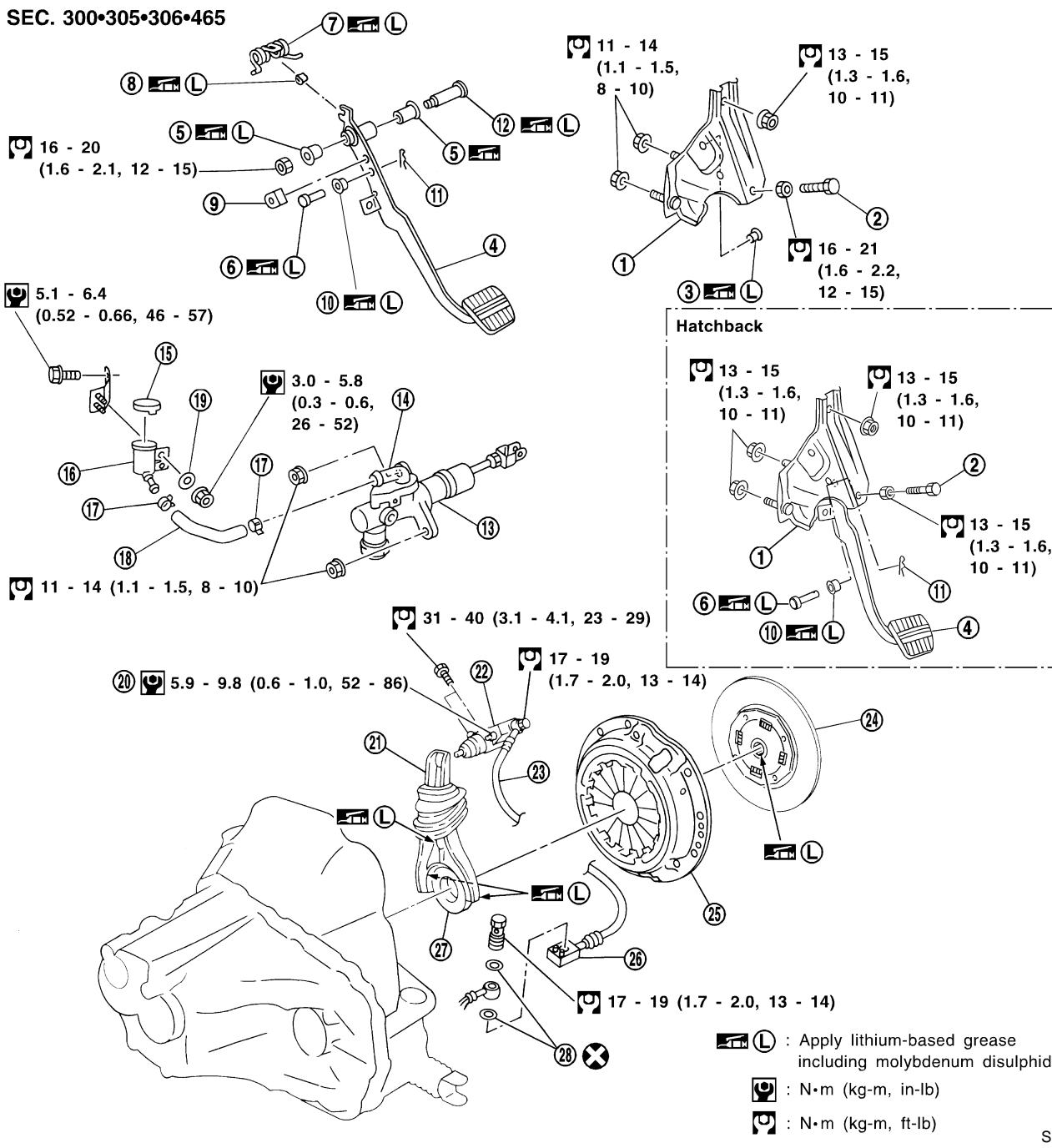

SCL845-A

- | | | |
|-------------------------|----------------------------|---------------------------|
| 1. Clutch pedal bracket | 11. Snap pin | 20. Air bleeder screw |
| 2. Pedal stopper bolt | 12. Fulcrum pin | 21. Withdrawal lever |
| 3. Bush | 13. Clutch master cylinder | 22. Operating cylinder |
| 4. Clutch pedal | 14. Nipple | 23. Clutch hose |
| 5. Bush | 15. Reservoir cap | 24. Clutch disc |
| 6. Clevis pin | 16. Reservoir tank | 25. Clutch cover |
| 7. Assist spring | 17. Hose clamp | 26. Clutch hose connector |
| 8. Bush | 18. Hose | 27. Release bearing |
| 9. Stopper rubber | 19. Washer | 28. Washer |
| 10. Bush | | |

CLUTCH SYSTEM

Components — LHD Model with YD Engine —

Components — LHD Model with YD Engine —

NJCL0049

SEC. 300•305•306•465

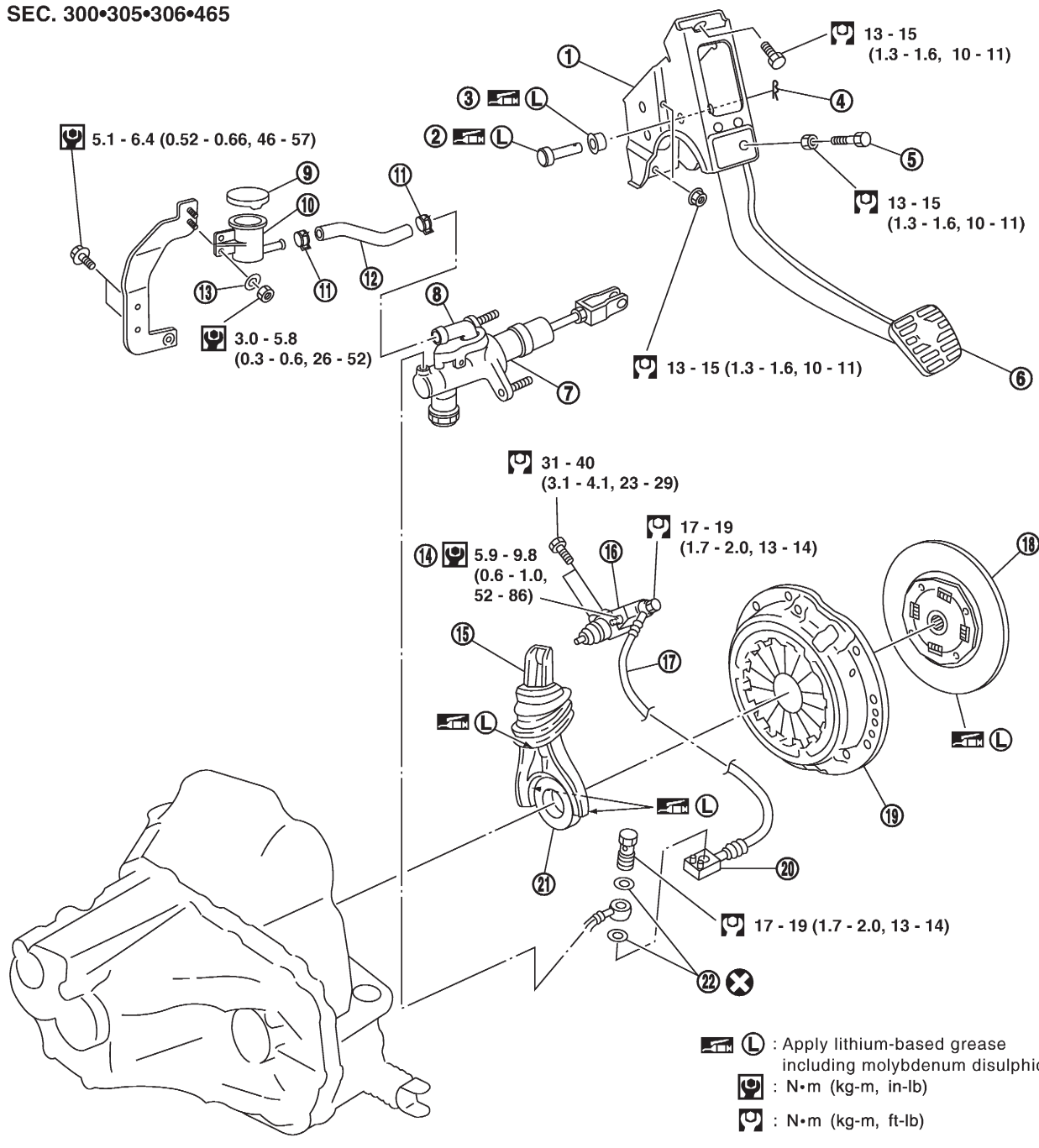

SCL846

- | | | |
|---------------------------|-----------------------|---------------------------|
| 1. Clutch pedal bracket | 9. Reservoir cap | 16. Operating cylinder |
| 2. Clevis pin | 10. Reservoir tank | 17. Clutch hose |
| 3. Bush | 11. Hose clamp | 18. Clutch disc |
| 4. Snap pin | 12. Hose | 19. Clutch cover |
| 5. Pedal stopper bolt | 13. Washer | 20. Clutch hose connector |
| 6. Clutch pedal | 14. Air bleeder screw | 21. Release bearing |
| 7. Clutch master cylinder | 15. Withdrawal lever | 22. Washer |
| 8. Nipple | | |

Inspection and Adjustment

CLUTCH PEDAL INSPECTION

NJCL0006

NJCL0006S03

Pedal Stroke

NJCL0006S0301

Check clutch pedal stroke by using a 1-meter rule to measure the total pedal stroke. Place end of rule onto the middle of the clutch pedal pad. Place a book/clipboard on the driver's seat to set a reference point, ensure the book/clipboard does not move during pedal depression. Mark (A) the pedal fully up position on the rule. Depress the clutch pedal and mark (B) the rule again next to the reference point on the book/clipboard. Measure the distance between the marks (A and B), this is the actual pedal stroke (S). Check the specified pedal stroke in the table, adjust actual pedal stroke if necessary (refer to "CLUTCH PEDAL ADJUSTMENT").

NOTE:

- Do not use steering wheel as a reference point, angle gives incorrect reading.
- Ensure there is no interference between the floor carpet and clutch pedal when fully depressed.

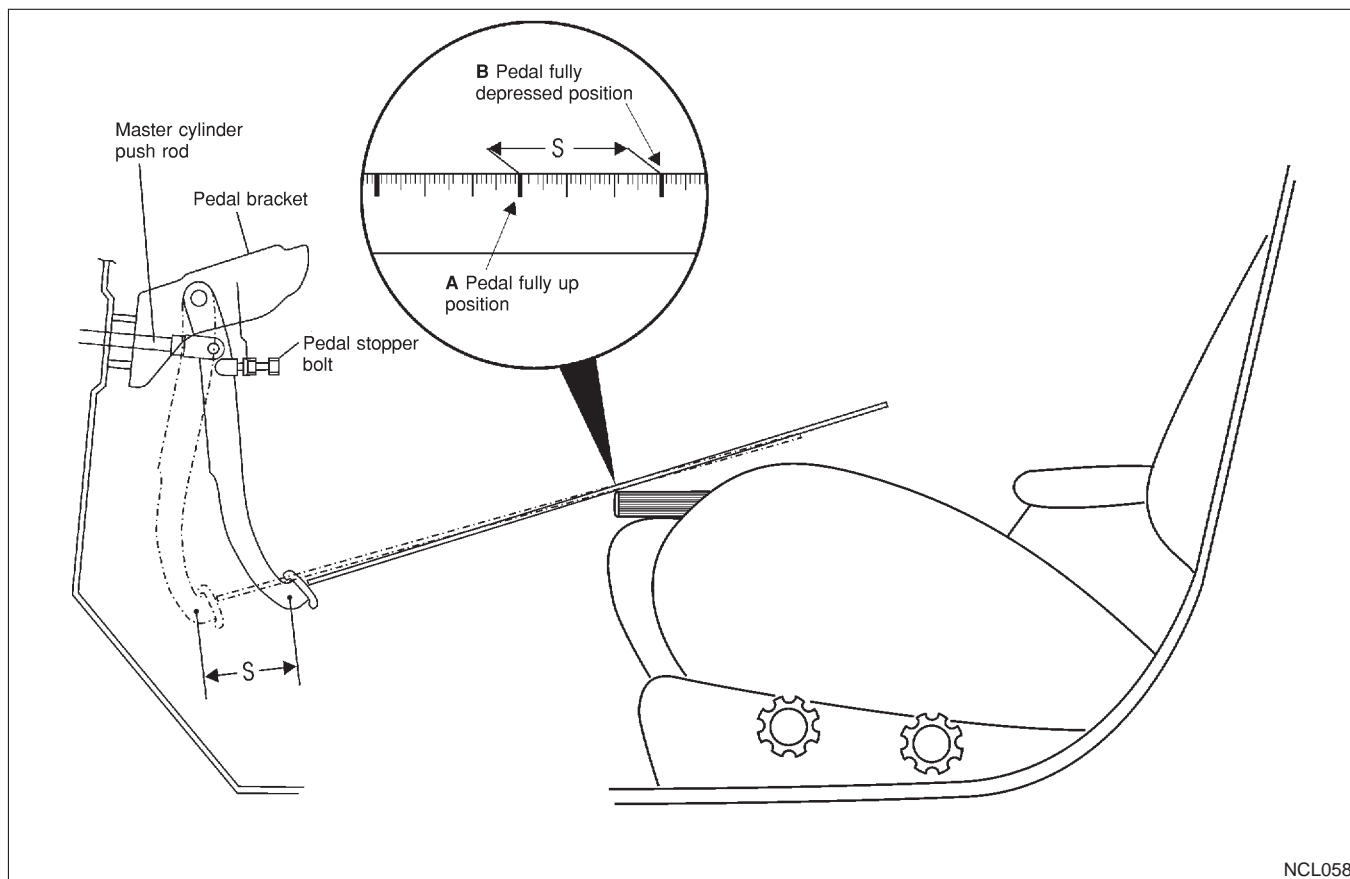

NCL058

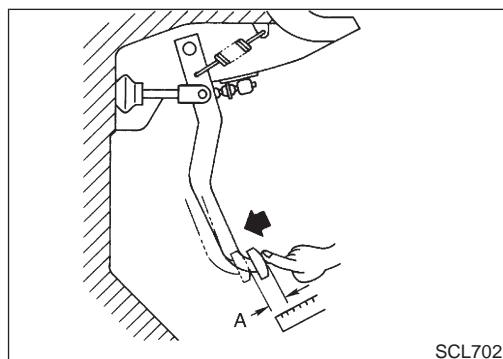

SCL702

Pedal Free Play

NJCL0006S0302

Check pedal free play, if out of specification refer to "CLUTCH PEDAL ADJUSTMENT"

- Push on the clutch pedal until resistance is felt, and check the distance the pedal moves.

CLUTCH SYSTEM

Inspection and Adjustment (Cont'd)

CLUTCH PEDAL ADJUSTMENT

NJCL0006S04

Pedal Stroke

NJCL0006S0401

1. Loosen the pedal stopper bolt completely (so there is no contact between pedal and stopper bolt).
2. Adjust pedal stroke to the specified value with the master cylinder push rod.
3. Adjust the pedal stopper bolt until it is just in contact with the pedal, then tighten the lock nut.
4. Once stroke is set to specification, adjust clutch pedal free play.

Pedal stroke "S".

Refer to "SDS", CL-24.

Pedal Free Play

NJCL0006S0402

1. Adjust pedal free play to the specified value with the master cylinder push rod.
2. Tighten lock nut of the master cylinder push rod.
 - Push on the clutch pedal until resistance is felt, and check the distance the pedal moves.

Pedal free play "A".

Refer to "SDS", CL-24.

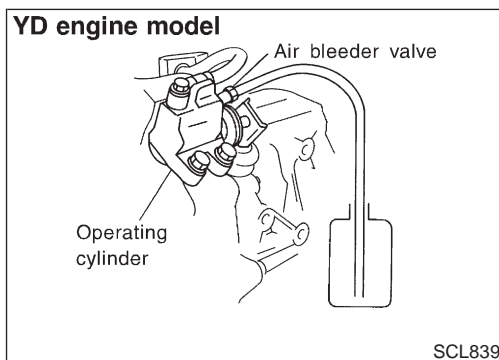
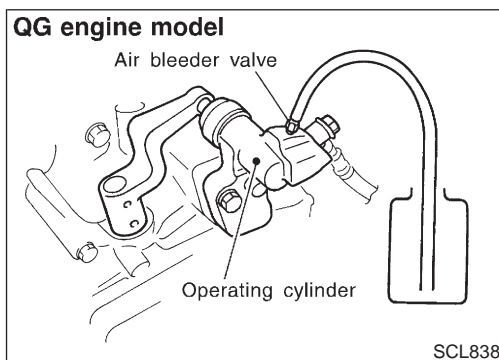

AIR BLEEDING PROCEDURE

NJCL0006S02

1. Bleed air from clutch operating cylinder according to the following procedure.
 - **Carefully monitor fluid level at master cylinder during bleeding operation.**
 - a. Top up reservoir with recommended brake fluid.
 - b. Connect a transparent vinyl tube to air bleeder valve.
 - c. Slowly depress the clutch pedal to its full stroke and release it completely. Repeat this operation several times at 2 to 3 seconds intervals.
 - d. Open the air bleeder with the clutch pedal fully depressed.
 - e. Close the air bleeder.
 - f. Release the clutch pedal and wait at least 5 seconds.
 - g. Repeat steps c through f mentioned above, then air bubbles will no longer appear at the damper in the brake fluid.

Air bleeder valve tightening torque:

🔧 : 5.9 - 9.8 N·m (0.6 - 1.0 kg·m, 52 - 86 in·lb)

CLUTCH MASTER CYLINDER

Components

Components

NJCL0007

SEC. 305

RHD model

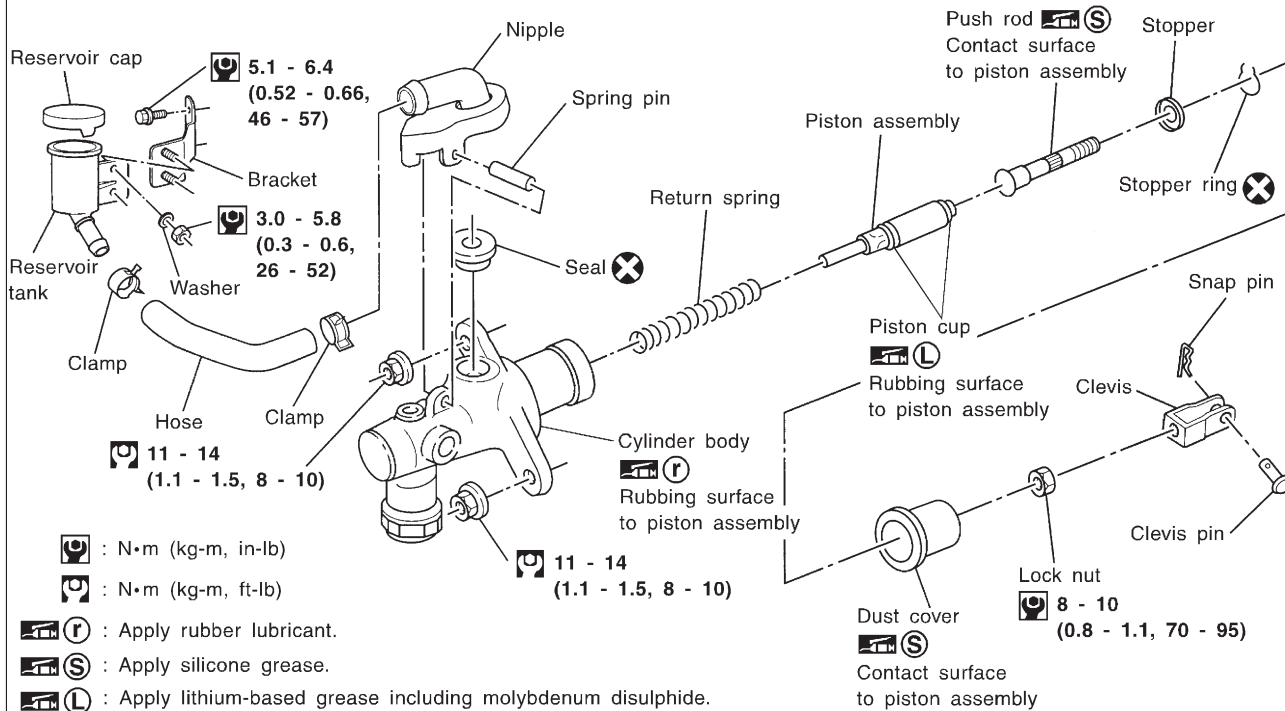

SCL840-A

SEC. 305

LHD model

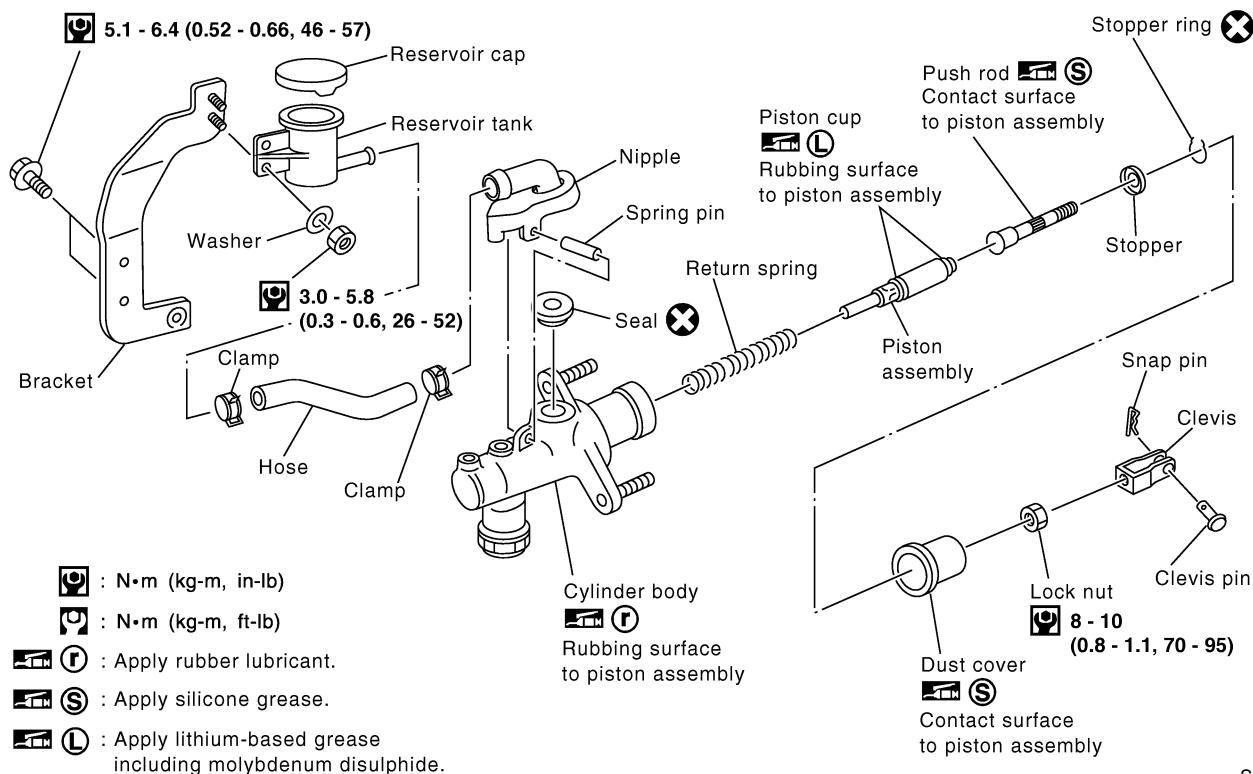

SCL847-A

CLUTCH MASTER CYLINDER

Removal

Removal

NJCL0008

1. Drain brake fluid.

CAUTION:

Be careful not to splash brake fluid on painted areas; it may cause paint damage. If brake fluid is splashed on painted areas, wash it away with water immediately.

2. Remove clutch tube using a flare nut wrench.
3. Remove snap pin between clutch pedal and push rod, and remove clevis pin.
4. Unscrew master cylinder assembly mounting nuts and remove master cylinder assembly from vehicle.

Installation

NJCL0009

1. Connect clutch tube to master cylinder assembly, and hand-tighten flare nut.
2. Install master cylinder assembly to vehicle, and tighten mounting nuts to the specified torque.
⚙️ : 11 - 14 N·m (1.1 - 1.5 kg·m, 8 - 10 ft·lb)
3. Tighten clutch tube flare nut using a flare nut torque wrench.
⚙️ : 15 - 18 N·m (1.5 - 1.8 kg·m, 11 - 13 ft·lb)
4. After installing clevis pin, install snap pin to connect clutch pedal to push rod.
5. After finishing the operation, bleed air from clutch piping connector and operating cylinder. (Refer to "Air Bleeding Procedure", CL-10.)

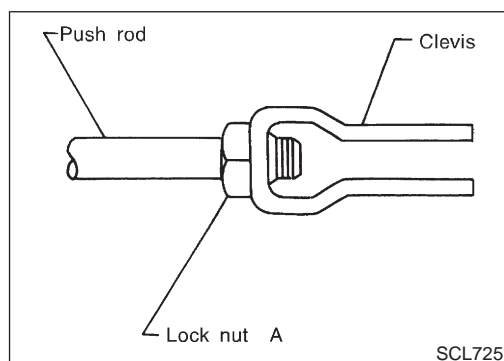

Disassembly

NJCL0010

1. Loosen push rod lock nut A to remove clevis and lock nut A.
2. Remove dust cover.
3. Remove stopper ring and stopper, and remove push rod from cylinder body. During removal, keep push rod depressed, to prevent piston inside master cylinder from popping out.
4. Remove piston assembly from cylinder body.

Inspection

NJCL0011

Check the following items, and replace if necessary.

- Rubbing surface of cylinder and piston, for uneven wear, rust or damage
- Piston with piston cup, for wear or damage
- Return spring, for wear or damage
- Dust cover, for cracks, deformation or damage
- Reservoir, for deformation or damage

CLUTCH MASTER CYLINDER

Assembly

Assembly

1. Apply rubber lubricant to the sliding part of piston assembly, and insert piston assembly. NJCL0012
2. After installing stopper to push rod, install stopper ring while keeping piston assembly depressed by hand, so that piston assembly will not pop out.

CAUTION:

Stopper ring cannot be reused. Always use a new stopper ring for assembly.

3. Install dust cover.
4. Install clevis to push rod, and tighten lock nut A to the specified torque.

 : 8 - 10 N·m (0.8 - 1.1 kg-m, 70 - 95 in-lb)

5. Install spring pin using a pin punch.

OPERATING CYLINDER

Components

Components

NJCL0019

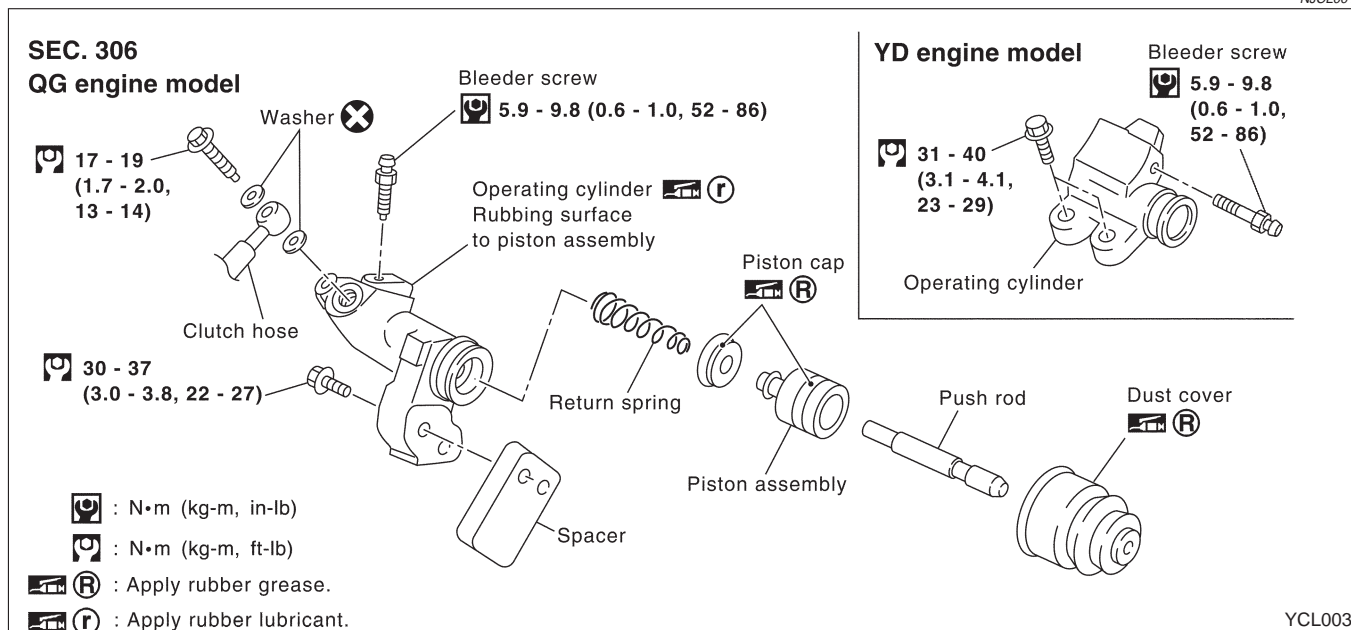

Removal

NJCL0020

1. Drain brake fluid.

CAUTION:

Be careful not to splash brake fluid on painted areas; it may cause paint damage. If brake fluid is splashed on painted areas, wash it away with water immediately.

2. Remove union bolt and clutch hose from operating cylinder.
3. Remove operating cylinder mounting bolts, and remove cylinder from vehicle.

Disassembly

NJCL0021

Remove dust cover, and remove piston assembly from cylinder body.

Inspection

NJCL0022

Inspect for following, and replace parts if necessary.

- Damage, foreign material, wear, rust, and pinholes on the cylinder inner surface, piston, and sliding part of piston cup
- Weak spring
- Crack and deformation of dust cover

Assembly

1. Apply recommended rubber grease to piston cup and piston, and insert piston assembly. NJCL0023
2. Install dust cover.

Installation

Install the components in the reverse order of removal. Adhere to the operations described below. NJCL0024

CAUTION:

Install the hose without twisting it.

- **The copper washer of the union bolt should not be reused. Always use a new copper washer for installation.**
- **After finishing the operation, bleed air from the clutch piping connector and operating cylinder. Refer to “Air Bleeding Procedure”, CL-10.**

PIPING

Removal

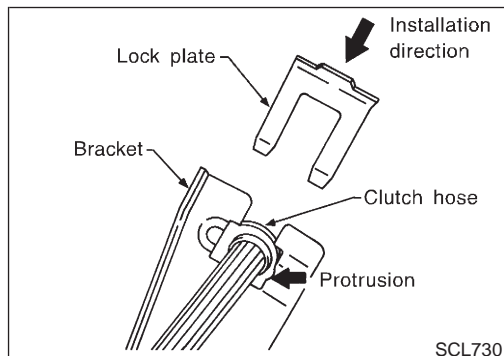
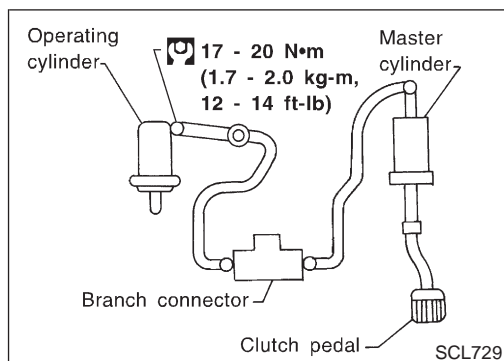

Removal

NJCL0042

1. Remove fuel filter mounting bracket.
2. Remove air cleaner and air duct.
3. Drain brake fluid.

CAUTION:

Be careful not to splash brake fluid on painted areas; it may cause paint damage. If brake fluid is splashed on painted areas, wash it away with water immediately.

4. Remove flare nut using a flare nut wrench.
5. Remove clutch hose and clutch tube.

Installation

NJCL0043

1. When installing clutch hose to bracket, face lock plate in the correct direction as shown to secure clutch hose.

CAUTION:

Install clutch hose without twisting or bending it.

2. Tighten flare nut to the specified torque, using a flare nut wrench.

 : 15 - 18 N·m (1.5 - 1.8 kg-m, 11 - 13 ft-lb)

CAUTION:

Be careful not to damage flare nut and clutch tube.

3. Install clutch hose to operating cylinder, and tighten mounting bolts to the specified torque.

 : 17 - 19 N·m (1.7 - 2.0 kg-m, 13 - 14 ft-lb)

4. After finishing the operation, bleed air from the clutch piping. Refer to "Bleeding Procedure", CL-10.

Components

NJCL0044

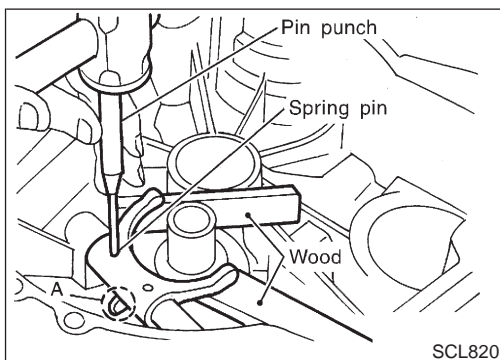
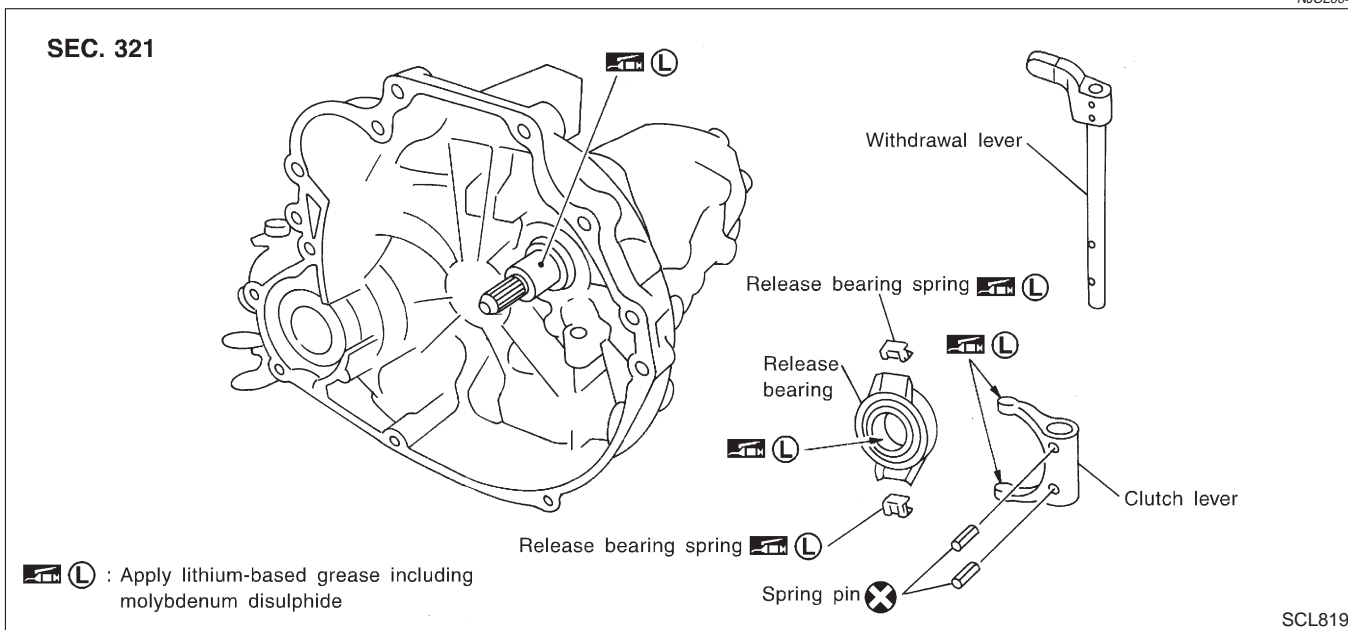

Removal

NJCL0045

1. Remove manual transaxle from vehicle. Refer to MT-24, "Removal".
2. Move withdrawal lever enough to remove release bearing, and remove release bearing from clutch lever.
3. Support clutch lever claws with an appropriate wood block, align retaining pin with A in the figure, and drive out spring pin using a pin punch.
4. Pull out withdrawal lever and remove clutch lever.

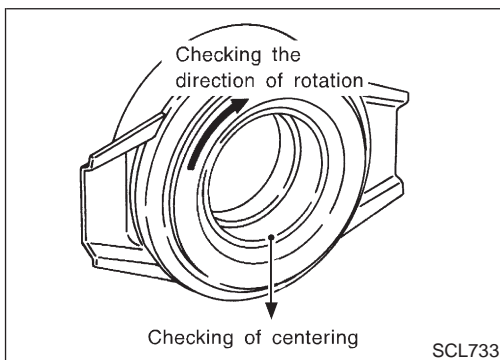

Inspection

NJCL0046

- Replace the release bearing if it is seized, damaged, faulty in rotation direction, or has poor aligning function.
- Replace the withdrawal lever if its contact surface is worn abnormally.
- Replace the clutch lever if its contact surface is worn abnormally.
- Replace the dust seal if it is deformed or cracked.

Installation

NJCL0047

CAUTION:

- Be sure to apply grease to the clutch components. Otherwise, abnormal noise, poor clutch disengagement, or clutch damage may occur. Wipe the excess grease off completely, because it may cause the clutch components to slip and shudder.
- Keep the clutch disc facing, pressure plate, and flywheel free of oil and grease.
- Clean old grease and abrasive materials off the grease application area.

CLUTCH RELEASE MECHANISM

RS5F30A, RS5F70A

Installation (Cont'd)

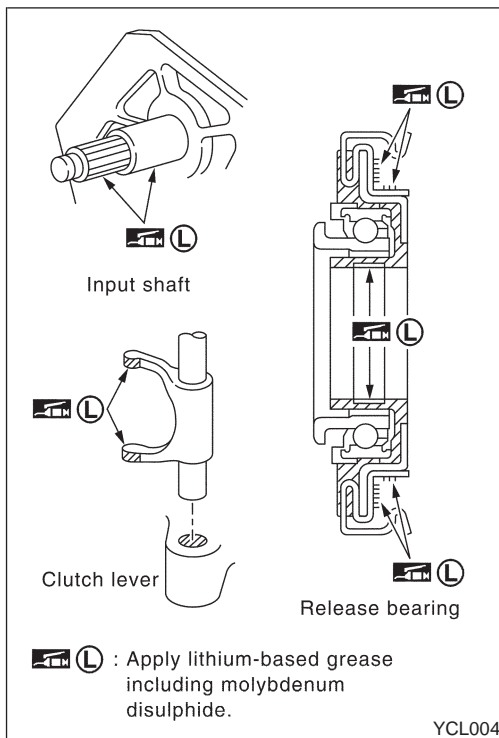

- Apply approximately 1 mm (0.04 in)-thick clutch sleeve grease evenly on the sliding part of the clutch lever and the release bearing spring.
- Apply just enough clutch sleeve grease to fill up the release bearing inner groove.
- Apply the clutch sleeve grease to the clutch disc and the input shaft spline. Install the clutch disc to the input shaft, remove the excess grease around the shaft, and remove the clutch disc.
- Lightly and evenly apply the clutch sleeve grease on the sliding part of the release bearing, install the release bearing, remove the excess grease around the bearing, and remove the release bearing.

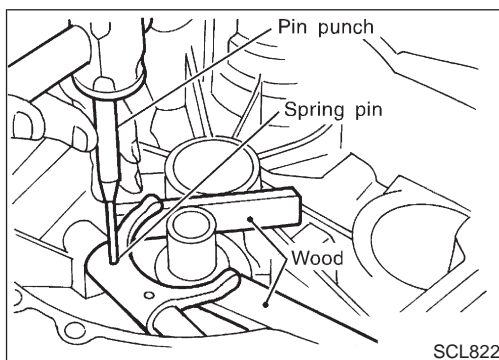

1. Assemble clutch lever to clutch housing, and insert withdrawal lever.
2. Support clutch lever claws with an appropriate wood block, and install a new spring pin using a pin punch.

CAUTION:
Spring pin cannot be reused.

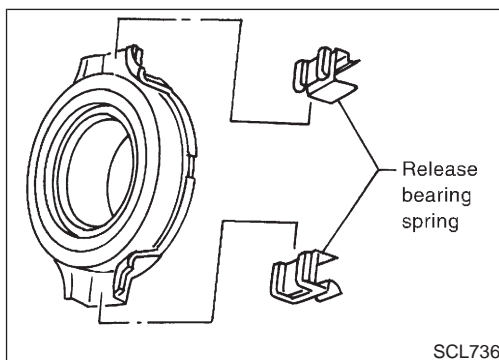

3. Install release bearing spring to release bearing as shown in the figure.

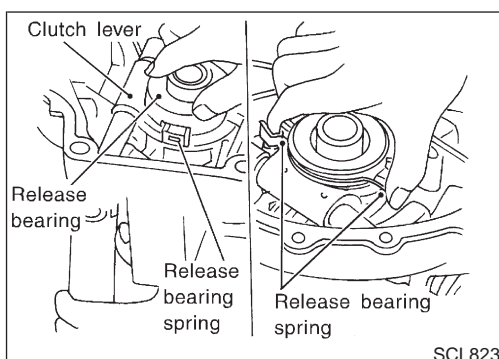

4. Operate withdrawal lever manually, press clutch spring from both sides, and install release bearing to clutch lever securely.
5. Make sure a click is heard when release bearing spring is pressed from both sides.

CLUTCH RELEASE MECHANISM

RS5F30A, RS5F70A

Installation (Cont'd)

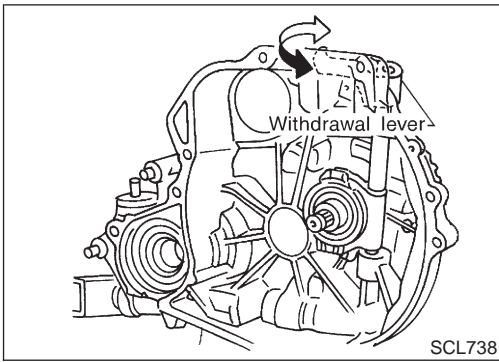

6. Make sure each sliding part operates smoothly when withdrawal lever is moved.

CAUTION:
Remove any excess grease with a shop towel.

Components

NJCL0027

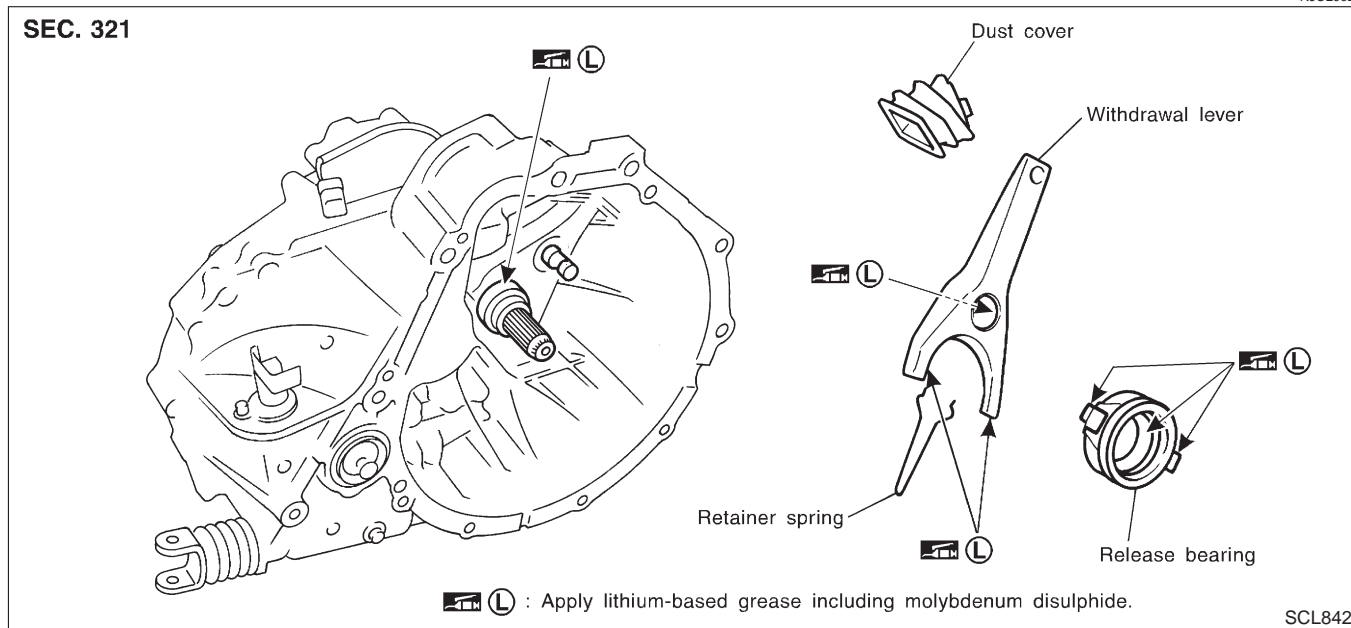

Removal

NJCL0028

1. Remove manual transaxle from vehicle. Refer to MT-27, "Removal".
2. Move withdrawal lever enough to remove release bearing, and remove release bearing from clutch withdrawal lever.
3. Remove dust cover.
4. Remove retainer spring from withdrawal lever.

Inspection

NJCL0029

- Replace the release bearing if it is seized, damaged, faulty in rotation direction, or has poor aligning function.
- Replace the withdrawal lever if its contact surface is worn abnormally.
- Replace the dust cover if it is deformed or cracked.

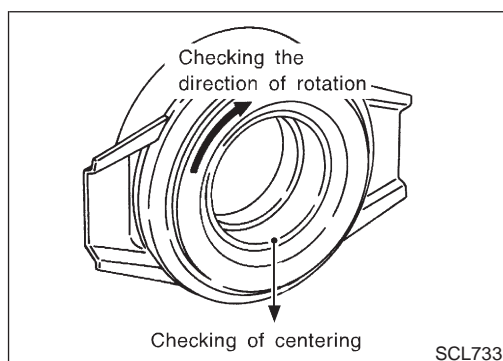

Installation

NJCL0030

1. Apply a coat of grease to parts as instructed in the following cautions and notes before installation.

CAUTION:

- Be sure to apply grease to the clutch components. Otherwise, abnormal noise, poor clutch disengagement, or clutch damage may occur. Wipe the excess grease off completely, because it may cause the clutch components to slip and shudder.
- Keep the clutch disc facing, pressure plate, and flywheel free of oil and grease.

CLUTCH RELEASE MECHANISM

RS5F50A

Installation (Cont'd)

- Clean old grease and abrasive materials off the grease application area.

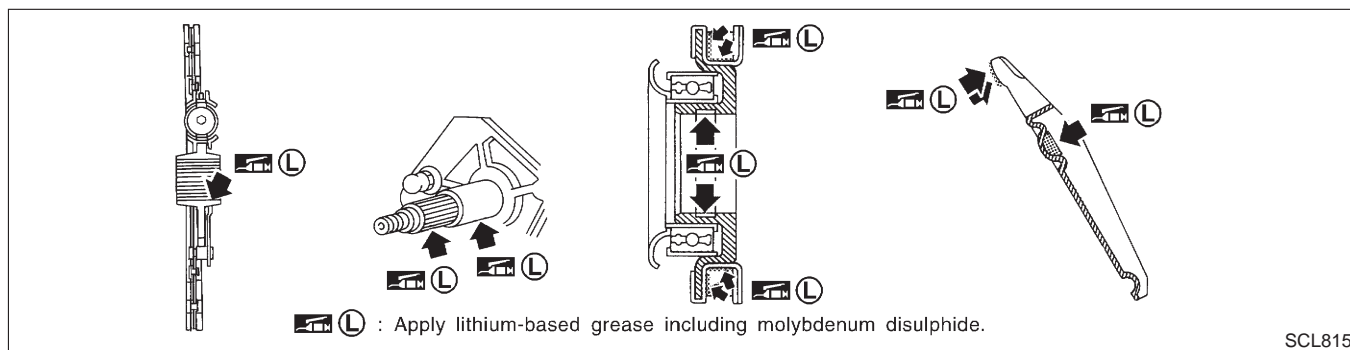

SCL815

NOTE:

- Equally apply a coat [approximately 1 mm (0.04 in) thick] of clutch sleeve grease to withdrawal lever and holder spring frictional surfaces.
 - Apply a coat of clutch sleeve grease to the grooves on contact surfaces of the withdrawal lever ball pin and inner surface of release bearing so that grease application, make sure that grease is flush with grooves.
 - Equally apply a thin coat of clutch sleeve grease to release bearing frictional surface. After grease application, install release bearing. Wipe off excess grease forced out during bearing installation. Remove release bearing.
2. Installation is in the reverse order of removal.

CLUTCH DISC, CLUTCH COVER AND FLYWHEEL

Components

Components

NJCL0031

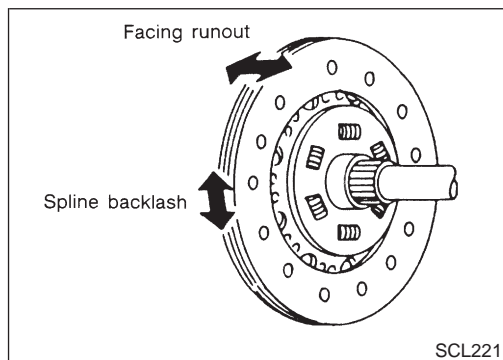
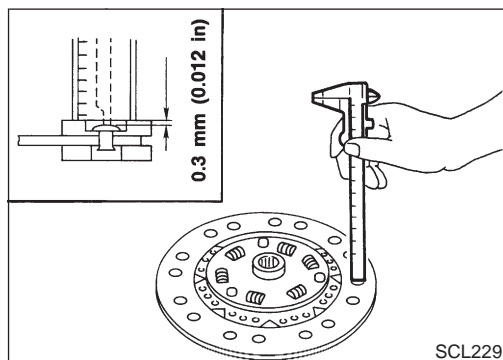
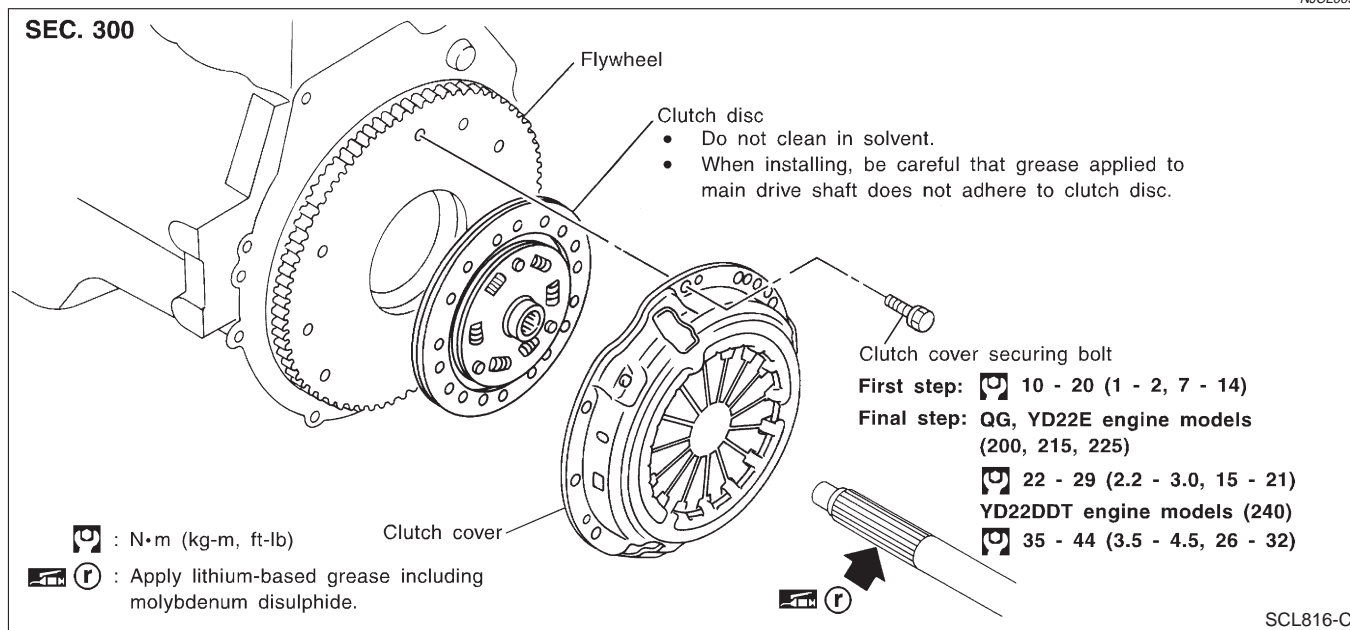

Inspection and Adjustment

NJCL0032

CLUTCH DISC

NJCL0032S01

- Check clutch disc for wear of facing.
 - Wear limit of facing surface to rivet head:**
MODEL 240, MODEL 200, MODEL 215 (Part number 30100-2F205)
 0.3 mm (0.012 in)
 - Wearing thickness of facing:**
MODEL 215 (Part number 30100-2F215)
 1.3 mm (0.051 in)
- Check clutch disc for backlash of spline and runout of facing.
 - Maximum spline backlash (at outer edge of disc):**
MODEL 200 0.8 mm (0.031 in)
MODEL 215 0.9 mm (0.035 in)
MODEL 240 1.0 mm (0.039 in)
 - Runout limit:**
 1.0 mm (0.039 in)
 - Distance of runout check point (from hub center):**
MODEL 200 95 mm (3.74 in)
MODEL 215 102.5 mm (4.04 in)
MODEL 240 115 mm (4.53 in)
- Check clutch disc for burns, discoloration or oil or grease leakage. Replace if necessary.

CLUTCH DISC, CLUTCH COVER AND FLYWHEEL

Inspection and Adjustment (Cont'd)

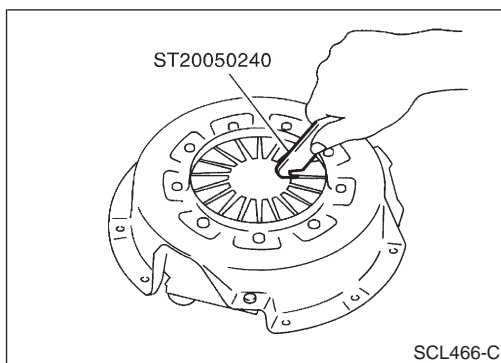

CLUTCH COVER

NJCL0032S02

- Check clutch cover installed on vehicle for unevenness of diaphragm spring toe height.

Uneven limit:

MODEL 200, 215 0.8 mm (0.031 in)

MODEL 240 0.7 mm (0.028 in)

- If out of limit, adjust the height with Tool.

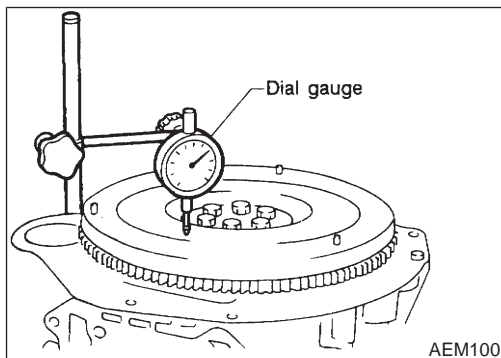

FLYWHEEL

NJCL0032S03

- Check contact surface of flywheel for slight burns or discoloration. Repair flywheel with emery paper.
- Check flywheel runout.

Maximum allowable runout:

Refer to EM-62, "Flywheel/Drive Plate Runout" (QG engine models), and EM-154, "Flywheel Runout (YD engine models)".

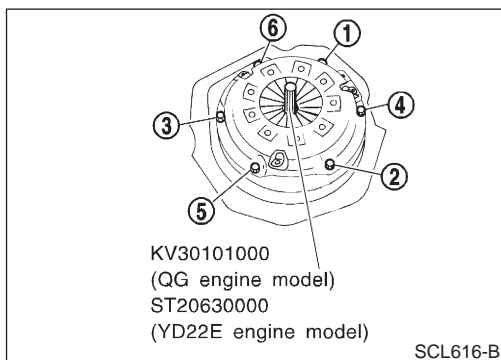

Installation

NJCL0033

- Insert Tool into clutch disc hub when installing clutch cover and disc.
- **Be careful not to allow grease to contaminate clutch facing.**
- Tighten bolts in numerical order.

First step:

☒ : 10 - 20 N·m (1 - 2 kg·m, 7 - 14 ft·lb)

Final step:

QG engine models (200, 215)

☒ : 22 - 29 N·m (2.2 - 3.0 kg·m, 15 - 21 ft·lb)

YD22DDT engine model (240)

☒ : 35 - 44 N·m (3.5 - 4.5 kg·m, 26 - 32 ft·lb)

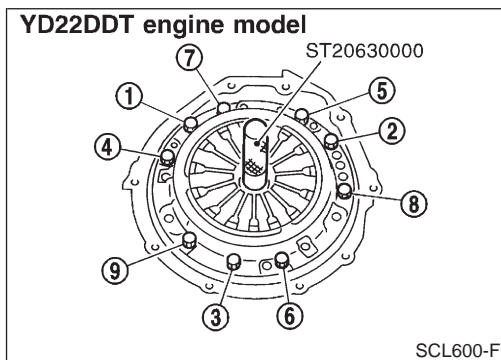

SERVICE DATA AND SPECIFICATIONS (SDS)

Clutch Control System

Clutch Control System

NJCL0034

| | |
|------------------------|-----------|
| Type of clutch control | Hydraulic |
|------------------------|-----------|

Clutch Master Cylinder

NJCL0035
Unit: mm (in)

| | |
|----------------|-------------|
| Inner diameter | 15.87 (5/8) |
|----------------|-------------|

Clutch Operating Cylinder

NJCL0036
Unit: mm (in)

| | |
|----------------|-------------|
| Inner diameter | 19.05 (3/4) |
|----------------|-------------|

Clutch Disc

NJCL0038
Unit: mm (in)

| Engine | QG15DE | QG18DE | | YD22DDT |
|--|---|---|--|---|
| Model | 200 | 215 | | 240 |
| | | Part number 30100-2F205 | Part number 30100-2F215 | |
| Facing size (Outer dia. × inner dia. × thickness) | 200 × 134 × 3.5 (7.87 × 5.28 × 0.138) | 215 × 140 × 3.5 (8.46 × 5.51 × 0.138) | 216 × 153 × 3.45 (8.50 × 6.02 × 0.1358) | 240 × 160 × 3.5 (9.45 × 6.30 × 0.138) |
| Thickness of disc assembly with load | 7.4 - 8.0 (0.291 - 0.315) with 3,780 N (385.6 kg, 849.7 lb) | 7.6 - 8.0 (0.299 - 0.315) with 4,904 N (500 kg, 1,103 lb) | 7.3 - 7.9 (0.2874 - 0.310) with 4,900 N (499.8 kg, 1,102 lb) | 7.85 - 8.35 (0.3091 - 0.3287) with 5,690 N (580.2 kg, 1,279 lb) |
| Wear limit of facing surface to rivet head | 0.3 (0.012) | 0.3 (0.012) | — | 0.3 (0.012) |
| Wearing thickness of facing | — | — | 1.3 (0.051) | — |
| Runout limit of facing | 1.0 (0.039) | | | |
| Distance of runout check point (from the hub center) | 95 (3.74) | 102.5 (4.04) | | 115 (4.53) |
| Maximum backlash of spline (at outer edge disc) | 0.8 (0.031) | 0.9 (0.035) | | 1.0 (0.039) |

Clutch Cover

NJCL0039
Unit: mm (in)

| Engine | QG15DE | QG18DE | YD22DDT |
|---|--------------------------|--------------------------|------------------------------|
| Model | 200 | 215 | 240 |
| Full-load | 3,481 N (355 kg, 783 lb) | 4,413 N (450 kg, 992 lb) | 5,690 N (580.2 kg, 1,279 lb) |
| Uneven limit of diaphragm spring toe height | 0.8 (0.031) | | 0.7 (0.028) |

Clutch Pedal

NJCL0040
Unit: mm (in)

| Applied model | Sedan | | | Hatchback |
|---------------------|----------------------------|----------------------------|----------------------------|----------------------------|
| | QG15DE | YD22DDT | QG18DE | |
| Pedal height "S" | 138 - 148 (5.43 - 5.83) | 138 - 148 (5.43 - 5.83) | 134 - 144 (5.28 - 5.67) | 140 - 150 (5.51 - 5.91) |
| Pedal free play "A" | 1 - 3 (0.039 - 0.118) | | | |